

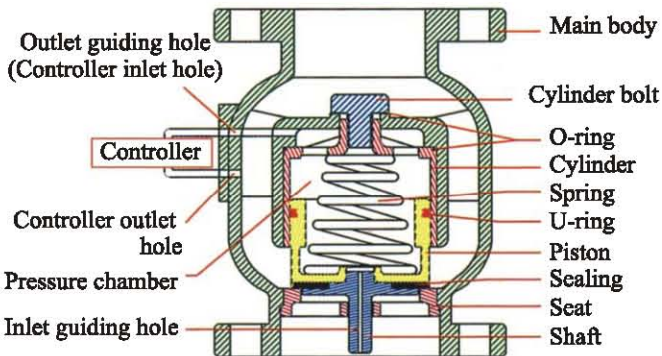

MULTI-FUNCTION AUTO-CONTROL VALVE

- ▶ Controller is fixed directly and designed of non-controller conduit. It reduces the damage of the controller conduit while transporting the equipment.
- ▶ Controller is designed to be quickly screw fastened, enabling fast and easy installation.
- ▶ The valve body can match with all types of controller without technical conversion, and all kinds of control valves can be formed.
- ▶ Cylinder design is adopted for the valve body structure, making the valve applicable to low and high pressure in both vertical and horizontal positions.
- ▶ Straight flow path is designed inside valve body. The large flow can reduce the malfunctions caused by impure water and effectively decrease turbulence and related bad effects.
- ▶ The valve body is shaped and formed as whole. Small volume, lightweight, and easy installation. Simple and elegant appearance.
- ▶ Professional manufacturers, best quality, and reasonable price.



▶ Patent Number : 135517

Part Name	Materials				
	Cast Iron	Ductile Iron	Bronze	SS 304	SS 316
Main body	Cast Iron	Ductile Iron	Bronze	SS 304	SS 316
Cylinder bolt	Cast Iron	Ductile Iron	Brass	SS 304	SS 304
O-ring	NBR	NBR	NBR	NBR	NBR / Viton
Cylinder	Bronze	Bronze	Bronze	SS 304	SS 316
Spring	SS 304	SS 304	SS 304	SS 304	SS 304
U-ring	NBR	NBR	NBR	NBR	NBR / Viton
Piston	Bronze	Bronze	Bronze	SS 304	SS 316
Sealing	NBR	NBR	NBR	NBR	NBR / Viton
Seat	Bronze	Bronze	Bronze	SS 304	SS 316
Shaft	Bronze	Bronze	Bronze	SS 304	SS 316
Controller	Brass	Brass	Brass	SS 304	SS 304

1. Applied conditions: Fluid & Air

2. Applied temperature: -15° ~ 80°C

3. Connection ends: Available for all international standards

4. Materials of valve body: Cast Iron, Ductile Iron, Bronze & Stainless Steel

The valve body of main valve becomes functional by an inlet-guiding hole. This hole transfers pressure to pressure chamber. When enough pressure accumulates in the pressure chamber, it generates pushing force that makes the piston close to valve seat and generates the closing motion. There is another outlet guiding hole inside the pressure chamber. When the hole is open, pressure in pressure chamber dissipates and valve gate is pushed open by incoming water pressure.

● Stock Items

Size	Flange End			
	Cast Iron	Ductile Iron	Bronze	Stainless Steel
2"	●	●	●	●
2.5"	●	●	●	●
3"	●	●	●	●
4"	●	●	●	●
5"	●	●	●	●
6"	●	●	●	●
8"	●	●	●	●
10"	●	●	●	●
12"	●	●	●	●
14"		●	●	●

(1 kgf/cm² = 14.2 psi)

Working Pressure		Test Pressure	
Cast Iron	: 16 kgf/cm ²	Cast Iron	: 24 kgf/cm ²
Ductile Iron	: 20 kgf/cm ²	Ductile Iron	: 30 kgf/cm ²
Bronze	: 16 kgf/cm ²	Bronze	: 24 kgf/cm ²
Stainless Steel	: 25 kgf/cm ²	Stainless Steel	: 38 kgf/cm ²

● Stock Items

Size	Thread End		
	Cast Iron	Bronze	Stainless Steel
1.5"		●	●
2"	●	●	

◎Production Size: 1.5"~ 56"



FIRE PROTECTION RELIEF VALVE (ANGLE TYPE)

- ▶ Designed to maintain safe water supply pressure inside fire protection system to prevent the sudden increased pressure that would damage the system. The Fire Protection Pressure Relief Valve can relieve the exceeded pressure automatically.
- ▶ The valve features an adjustable pressure setting, fast opening to maintain the steady line pressure and close gradually as pressure decrease below the set point.



Pressure Adjusting Range : 1~6 kgf/cm²
(1 kgf/cm² = 14.2 psi) 4~10 kgf/cm²

Applied Temperature : -15~60 °C

Valve Body Testing Pressure : 24 kgf/cm²

Maximum Applied Pressure : 25 kgf/cm²

◎ Special order can be arranged for higher pressure adjustment range.

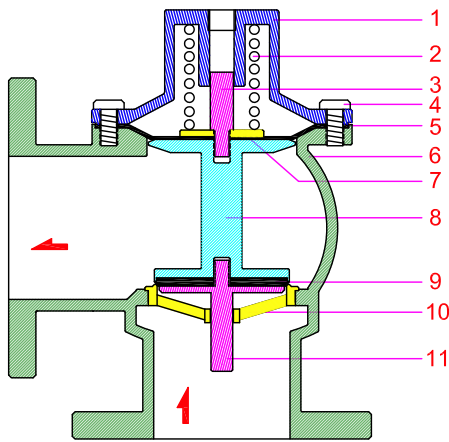

No	Part Name	Material
1	Valve Cover	Ductile Iron
2	Spring	Stainless Steel
3	Shaft	Bronze
4	Fixed Bolt	Stainless Steel
5	Diaphragm	CR Rubber
6	Main Body	Ductile Iron
7	Diaphragm Washer	Stainless Steel
8	Diaphragm Fixed Bar	Bronze
9	Sealing Spacer	NBR
10	Seat	Bronze
11	Center Shaft	Bronze
	Control Pipe line	Bronze
A	Ball Valve	Bronze
B	Relief Pilot Valve	Stainless Steel
C	Needle Valve	Stainless Steel

(Flange End)

Item No	Size	H(mm)	L(mm)	CV
BFL-F	4"	340	180	210

